



Installing Full-Race F150 EcoBoost Cold Air Intake

This article documents the installation of our [F150 FreakoBoost Cold Air Intake](#). This innovative bolt-on design draws fresh, cool air from the front of the vehicle - not from the wheel well or engine bay. Install is straight forwards and requires basic mechanical skills and hand tools. The entire job can be performed with the truck on the ground in under 30 minutes - no need to use a lift.



1. Starting with a stock EcoBoost F150: first open the hood, then disconnect the battery.
2. Unplug/Unscrew Intake sensor. Safely set sensor aside. (2011 square sensor on left, 2012-2016 round sensor on right)



3. Loosen clamps #7, #5, #6, #8 (optional). Unclip lower airbox #1. Remove filter element #4, Merge pipe #9 and upper airbox #3.

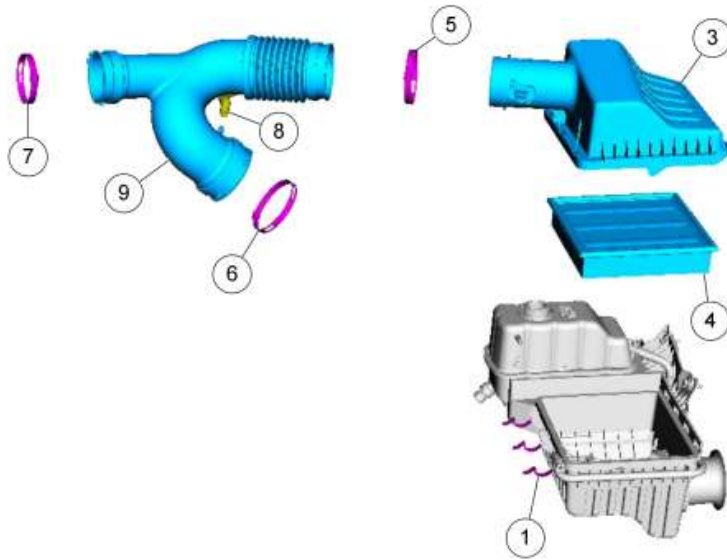

4. On 2011-2014 F150s: Remove the 2 large rubber flaps (red arrows) - these block fresh airflow:

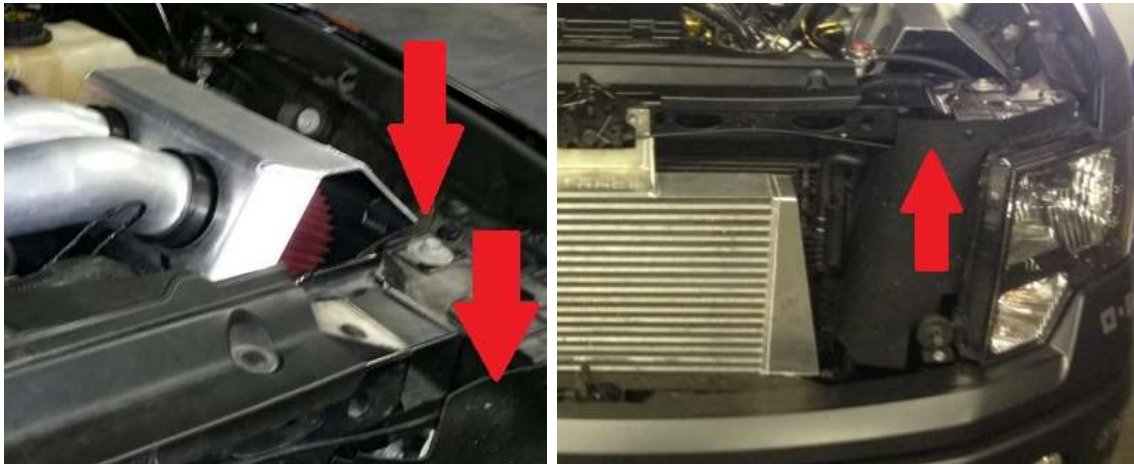

5. Next, we suggest to remove the “attenuators” from the intake tubes. Some people call them “vornados” others call them “pinwheels” or “whirlygigs”. Whatever you call them, they are not mandatory to remove - but recommended. Their only purpose is to muffle and quiet the cool noises from your turbo.



6. Now, everything is removed so we can start by installing the couplers and clamps.



7. Place the 3" straight coupler/clamps on the passenger side and 4" -> 3" transition "step coupler"/clamps on driver side.



8. Next, Install this plug in the lower airbox. It will reduce moisture in the wheel well from getting drawn into the intercooler and turbo while driving in wet/rainy conditions



9. Install the airfilter upper housing with air filter elements. Align tabs, lock in clips. Keep airfilter elements loosely in position.



10. Align the rear intake pipe/filter/clamp. Inspect coupler and filter/housing alignment, then tighten. This rear filter can be tricky to align on 2011-2014. It is easier on 2015+.



11. Align the front intake pipe/filter/clamp. Inspect coupler and filter/housing alignment, then tighten.



12. Install intake sensor, and plug in. 2011 in front pipe, 2012-2016 in rear pipe.



13. 2015+ only – install airfilter cover lid



14. Inspect the install. Check all hose clamps for tightness, without being overtightened. Check sensor installation and plug. Check air box clips. If everything checks out - connect battery, start engine.

